



S P E C S

**Jensen Precast
Type 1 Split Box Culvert**

**AASHTO HS-20 Traffic Loading
In Accordance with**

**ASTM C1433
ACI 318
and
AASHTO**

Corporate Engineering Office
460 Dunn Circle
Sparks, Nevada 89431-5803
Phone 775-352-2700
Fax 775-352-6364

FILE NO. TYPE 1-SBC-ASTM

MANUFACTURER OF PRECAST CONCRETE PRODUCTS

Jensen Split Box Culvert Structural Design Criteria

Jensen Precast Split Box Culvert structural calculations are based on the use of the design loadings as described in ASTM C1433 which is the successor of ASTM C789 and C850 (previously adopted by the American Association of State Highway and Transportation Officials as AASHTO standards M259 and M273). Additionally the calculations comply with the requirements of the American Association of State Highway and Transportation Officials Standard Specifications for Highway Bridges. All vertical and lateral forces as well as ultimate strength coefficients, shear equations, and crack control criteria meet or exceed these specifications.

These standards have been successfully used for the design and construction of box culvert projects in the State of Nevada, the State of Arizona, the State of California, and across the entire United States for many decades without specific modification due to local soil conditions. Additionally the ASTM standards C890 and C857 have been utilized successfully for underground Drainage, Telephone and Electrical Structures on a widespread basis. ASTM C890 and C857 allow for reduced soil loading and reduced ultimate strength coefficients when compared to ASTM Standard C1433 and the AASHTO Bridge Specifications.

Relative to seismic design for underground structures AASHTO, ASTM C1433, ASTM C789, ASTM C850, ASTM C890 and ASTM C857 do not require a seismic loading condition and structures designed to these criteria have successfully survived the worst of seismic events. The AASHTO Standard Specification for Highway Bridges specifically excludes earthquake loading from the load combination for culverts, Group X, in their table of loading coefficients and further addresses the issue in Section 3.1 of their specification with the statement "Seismic design is usually not required for buried type (culvert) bridges".

CalTrans further addresses the seismic issue relative to culverts with the following statement:

"Seismic forces are normally not considered in soil-structure interaction systems. Observations of all types of underground structures in the 1971 San Fernando earthquake area and in the 1989 San Francisco (Loma Prieta) earthquake area, affirmed the cushioning effect the soil has on the performance of an underground structure during an earthquake. There were no failures due to an increase in soil pressures. Underground structures must move with the surrounding soil during earthquakes and usually will be supported by the interacting earth against crushing or collapse even if the structure joints are strained. If the earth does fault across a culvert, the tremendous forces will shear the submerged structure regardless of how the structure was designed. In special cases where underground structures are in soft ground (bay mud) consideration should be given to providing longitudinal structural continuity."

In general, unless the actual seismic fault occurs through the structure, the rolling movement of the ground encapsulating the structure does not present a significant overload. If the fault does occur thru the structure the structure will shear regardless of its design.

Relative to the potential stability of an underground structure when it is exposed during future adjacent excavation, the normal OSHA requirements for either adequately sloped earth walls or providing specifically designed shoring applies.

Jensen Split Box Culvert Structural Design Criteria

(continued)

Box Culverts designed with cantilevered walls are generally not in danger of collapse when one side is exposed due to their design method. However, circular pipe and other arch type systems are almost totally dependent on a continuous sidewall and haunch bearing to prevent collapse and are much more prone to collapse due to adjacent excavation.

While there are instances where the potential sliding forces due to an exposed culvert surface can be totally resisted by soil friction, the actual specifics such as depth of adjacent excavation, parallel length of adjacent excavation, and the responsibility for Federal and State required excavation and shoring design must remain with the excavation contractor.

Recommended Jensen Split Box Culvert Installation Requirements

The successful installation of Jensen Split Box Culvert is highly dependent on proper preparation and grading of the sub-grade and base materials. Appropriate dewatering and maintenance of all water levels below the sub-grade elevation until the excavation is backfilled is required to assure that grades are maintained and the sub-grade and base material is not compromised.

Excavation and shoring shall be performed in accordance with all applicable Federal and State specific regulations and requirements. If Jensen personnel are assisting or performing installation services, the Jensen supervisor/competent person will perform an inspection of trenches and excavations prior to allowing Jensen personnel to proceed. To avoid jobsite delays please review our inspection checklist to assure compliance prior to scheduling installation.

Sub-grade materials shall be improved by compaction or replacement as directed by the project geotechnical engineer. A minimum of 4" thick base material shall be placed and compacted to 90 percent ASTM D558 density or as required by the project geotechnical engineer. The base material shall be fine graded to within ¼" of required grade prior to culvert placement. The attached drawing details the minimum base requirements.

Appropriately sized rigging and lifting equipment shall be selected and utilized to lift and place the culvert sections. Consult Jensen Precast regarding lifting weights and lifting connection equipment required specific to your project.

Review the project specific layout drawings prior to culvert placement to determine the appropriate starting end and direction of lay to avoid having to pull, push or "come along" sections together. The split box culvert sections are designed to be placed in a direction such that the tongue of the bottom section is placed down into the groove of the previously placed bottom section and the groove of the top section is placed down over the tongue of the previously placed top section. Attempting to place the culvert in the opposite direction will result in additional labor requirements as well as potentially disrupting the bedding material creating joint sealing issues. The attached drawing details the proper placement sequence.

To facilitate proper sealing of the sections it is imperative that two bottom sections are placed prior to the placement of the first top section and during the progression of the placement one bottom section always extends beyond the top section currently being placed. The attached drawings detail the proper sealant placement and sequence of sealing the joints.

If the culvert run is multi-barrel a 3 inch space shall be left between the parallel culverts. This gap shall be filled with grout or 1 ½ sack per cubic yard cement sand slurry and allowed to cure prior to backfilling the excavation to assure that all horizontal forces are uniformly transferred from outer sidewall to outer sidewall. Failure to do so can cause inner wall failure due to point loading the structure. The attached drawing details multi-barrel placement.

Backfill materials shall be placed uniformly on each side of the culvert run to avoid potential sliding of the culvert alignment during compaction. Backfill materials, compaction, depth of layers, and methods shall be as directed by the project geotechnical engineer.

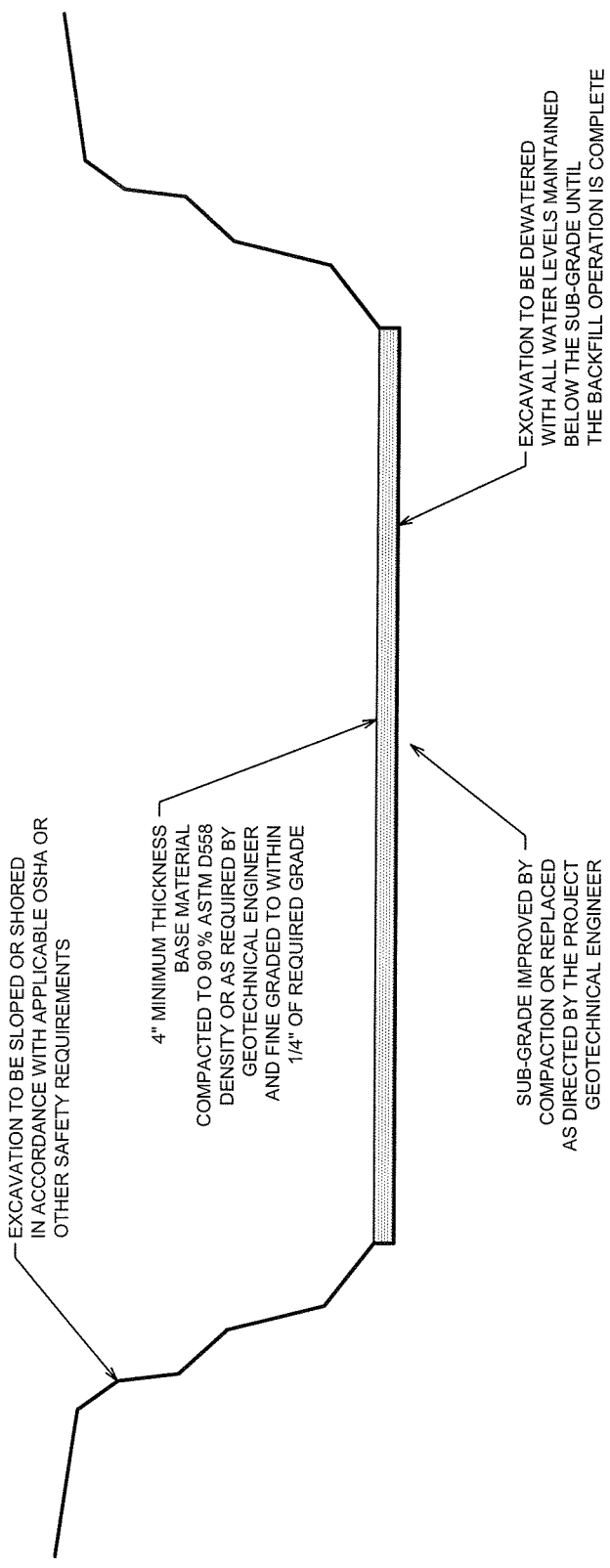

TYPE 1 SPLIT BOX CULVERT EXCAVATION AND BASE



THIS DOCUMENT AND THE DATA DERIVED HEREIN OR HEREWITH IS NOT TO BE REPRODUCED, USED OR DISCLOSED, IN WHOLE OR IN PART, WITHOUT THE WRITTEN PERMISSION OF JENSEN PRECAST.

3			
2			
1			
0	06-21-06	DATE	NEW DRAWING
REV.			DESCRIPTION

TYPE 1
BOX CULVERT
INSTALLATION
JENSEN PRECAST

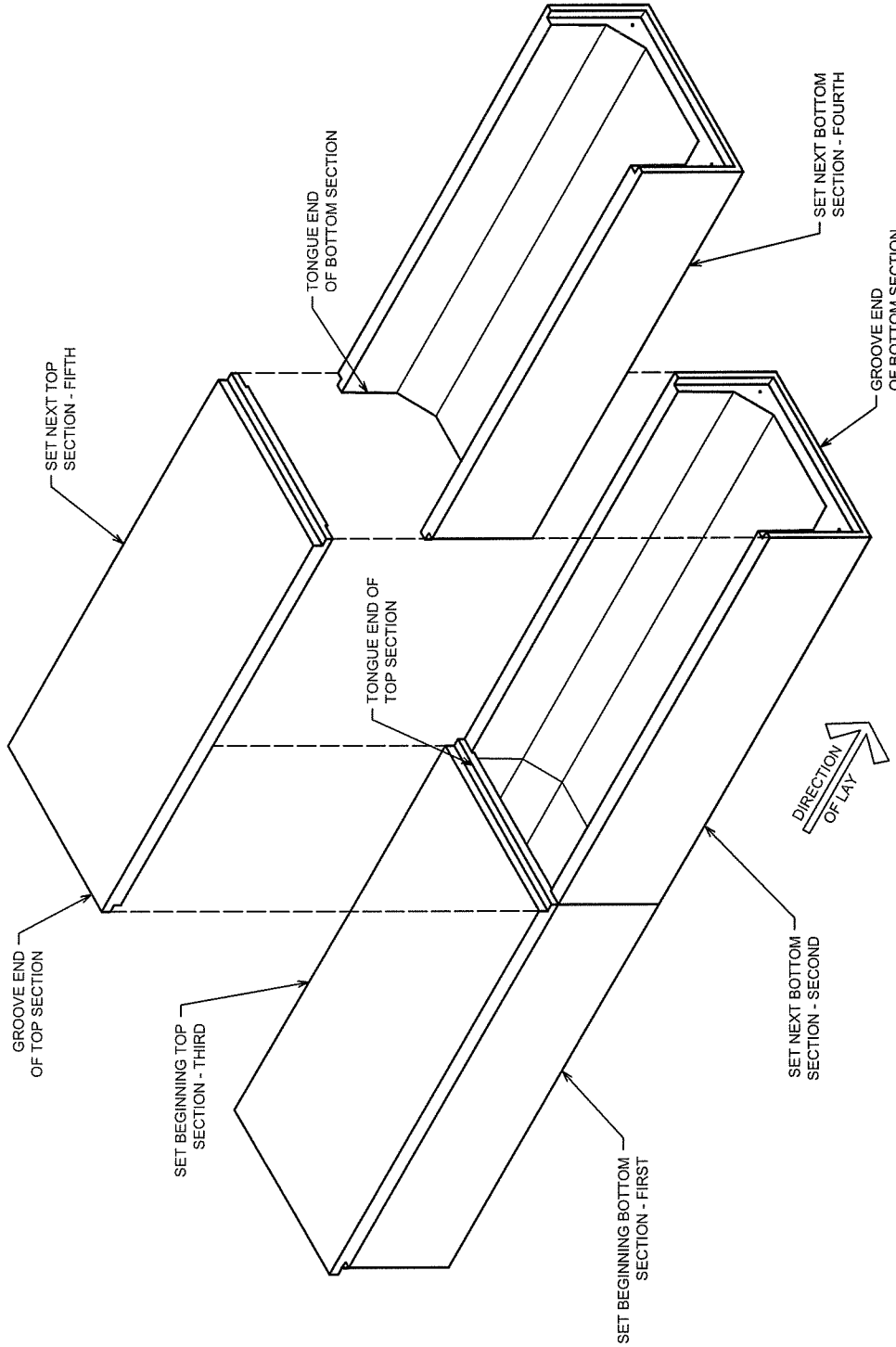

THIS DOCUMENT AND THE DATA DERIVED HEREIN OR HEREWITH
 IS THE PROPERTY OF JENSEN PRECAST. IT IS TO BE USED
 ONLY IN CONNECTION WITH THE PROJECT AND NOT TO BE
 REPRODUCED OR IN PART BY ANYONE WITHOUT THE WRITTEN PERMISSION
 OF JENSEN PRECAST.

REV.	DATE	DESCRIPTION
3		
2		
1		
0	06-21-06	NEW DRAWING

TYPE 1
 SPLIT BOX CULVERT
 INSTALLATION SEQUENCE
 JENSEN PRECAST

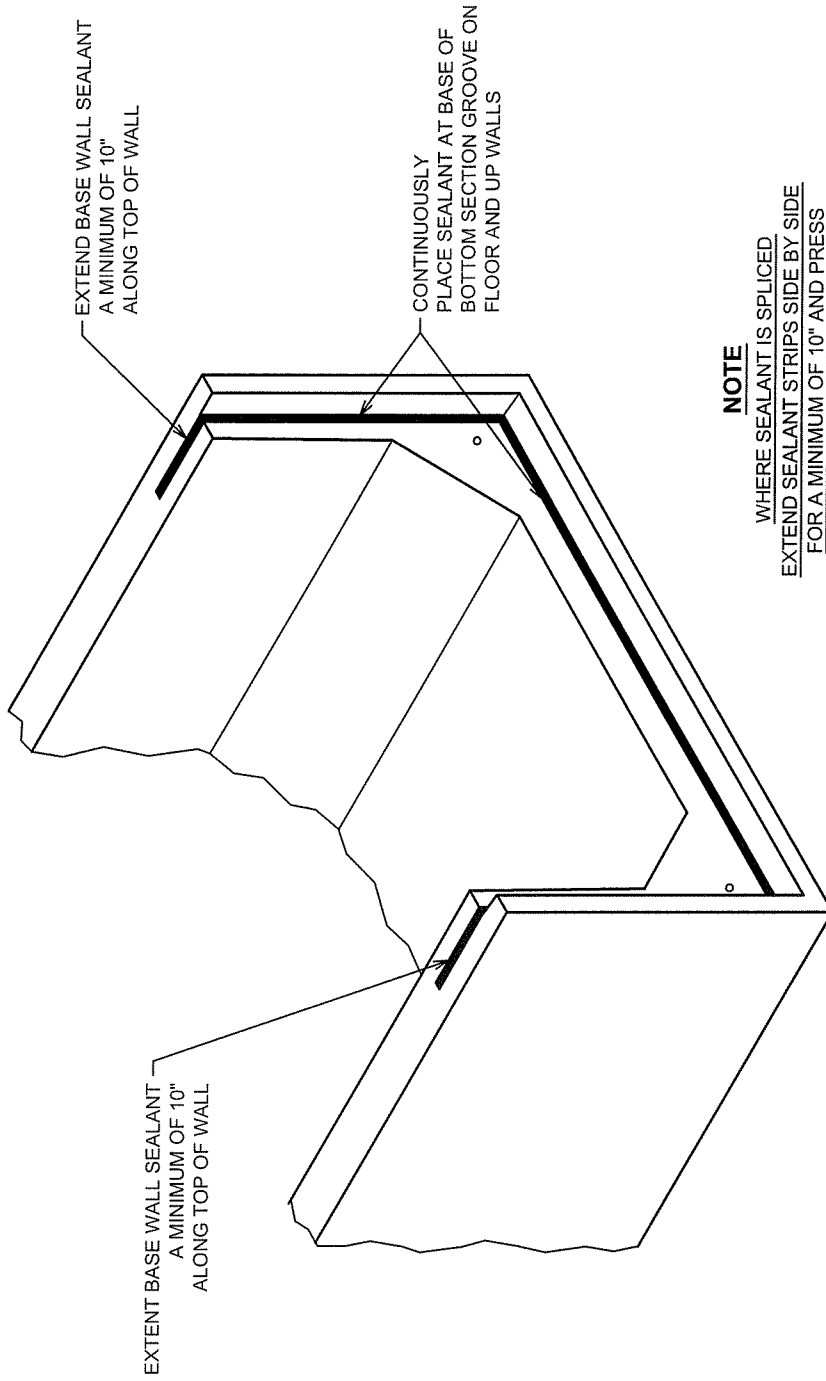

NOTE

WHERE SEALANT IS SPLICED
 EXTEND SEALANT STRIPS SIDE BY SIDE
 FOR A MINIMUM OF 10" AND PRESS
 SIDES OF SEALANT TOGETHER

STEP 1 - BOTTOM WALL AND FLOOR SEALANT

3		
2		
1		
0	06-21-06	NEW DRAWING
REV.	DATE	DESCRIPTION

TYPE 1
 SPLIT BOX CULVERT
 SEALANT PLACEMENT
 JENSEN PRECAST



THIS DOCUMENT AND THE DATA DERIVED HEREIN OR HEREAFTER
 IS NOT TO BE REPRODUCED, USED OR DISCLOSED, IN WHOLE
 OR IN PART, BY ANYONE WITHOUT THE WRITTEN PERMISSION
 OF JENSEN PRECAST.

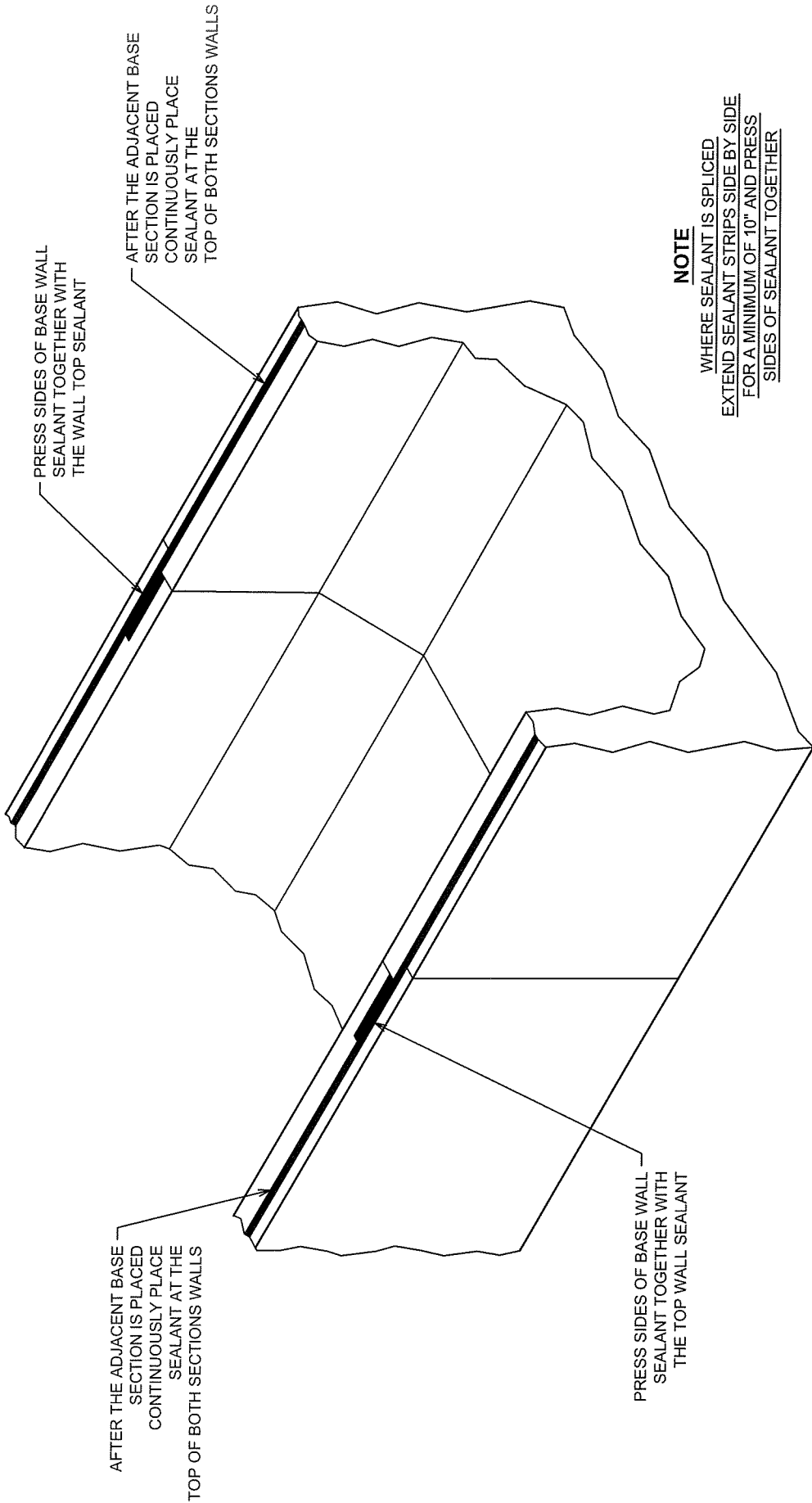

NOTE

WHERE SEALANT IS SPLICED
 EXTEND SEALANT STRIPS SIDE BY SIDE
 FOR A MINIMUM OF 10" AND PRESS
 SIDES OF SEALANT TOGETHER

STEP 2 - WALL TOP SEALANT PLACEMENT

3			
2			
1			
0	06-21-06	NEW DRAWING	
REV.	DATE	DESCRIPTION	



THIS DOCUMENT AND THE DATA DERIVED HEREIN OR HEREWITH IS NOT TO BE REPRODUCED, USED OR DISCLOSED IN WHOLE OR IN PART WITHOUT THE WRITTEN PERMISSION OF JENSEN PRECAST

TYPE 1
 SPLIT BOX CULVERT
 SEALANT PLACEMENT
 JENSEN PRECAST

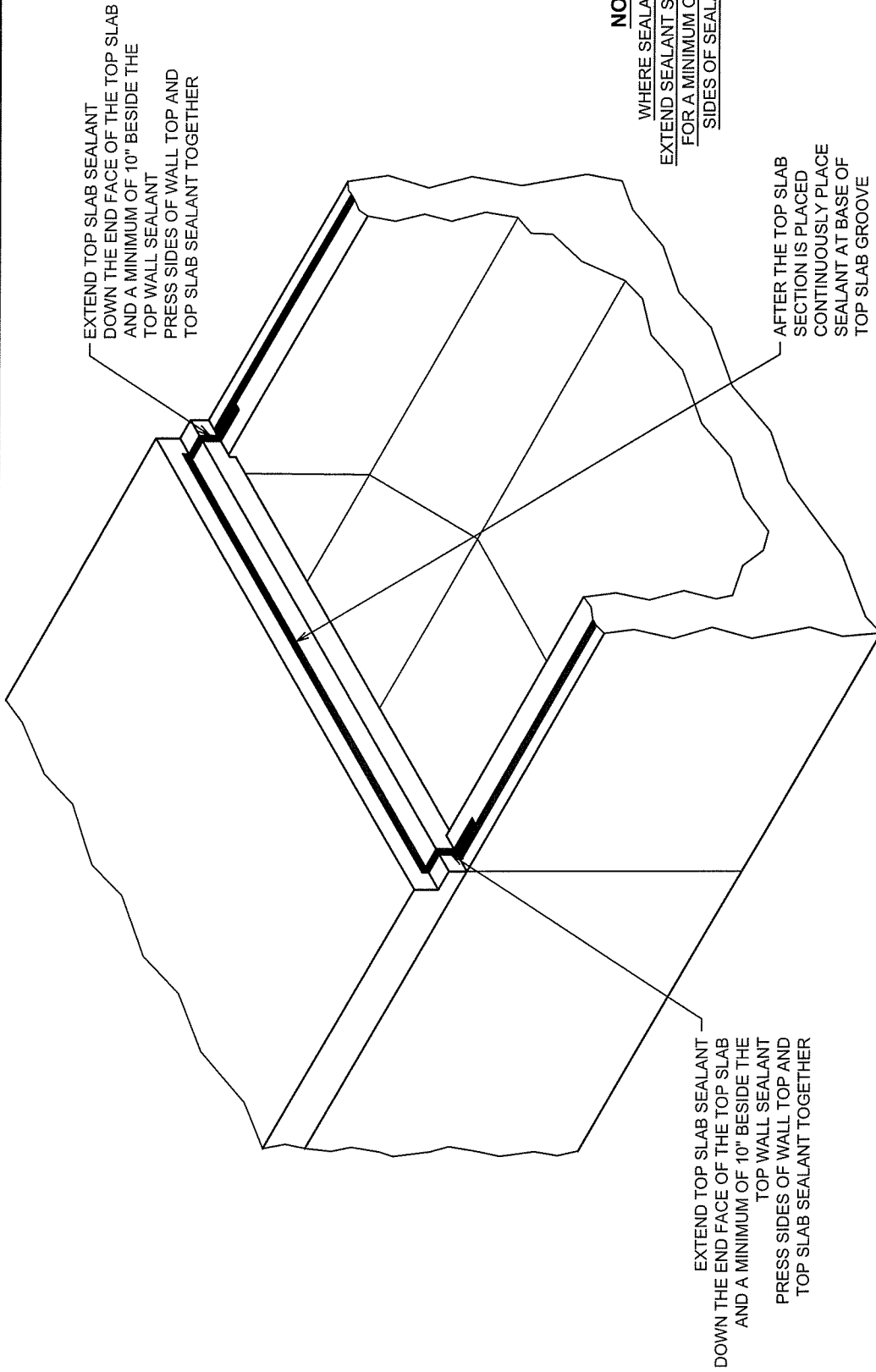

STEP 3 - TOP SLAB END SEALANT PLACEMENT

3			
2			
1			
0	06-21-06	DATE	NEW DRAWING
REV.			DESCRIPTION

TYPE 1
SPLIT BOX CULVERT
SEALANT PLACEMENT
JENSEN PRECAST



THIS DOCUMENT AND THE DATA DERIVED HEREIN OR HEREWITH
AND ANY INFORMATION CONTAINED HEREIN IS UNCLASSIFIED
EXCEPT WHERE SHOWN OTHERWISE. IT IS RELEASED IN WHOLE
OR IN PART BY ANYONE WITHOUT THE WRITTEN PERMISSION
OF JENSEN PRECAST.

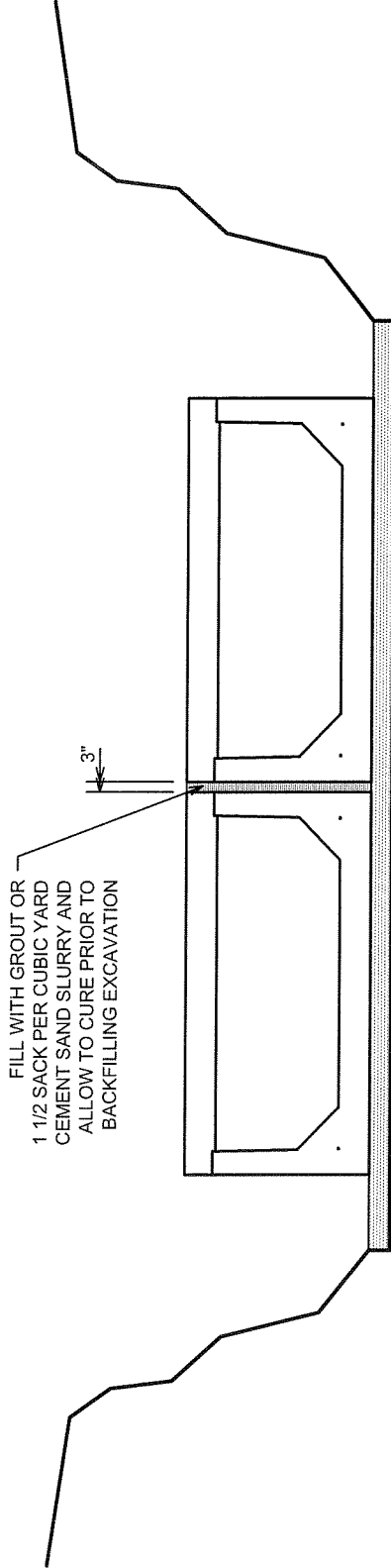

TYPE 1 SPLIT BOX MULTI BARREL INSTALLATION



THIS DOCUMENT AND THE DATA DERIVED HEREIN OR HEREWITH IS NOT TO BE REPRODUCED, USED OR DISCLOSED, IN WHOLE OR IN PART, BY ANYONE WITHOUT THE WRITTEN PERMISSION OF JENSEN PRECAST.

3		
2		
1		
0	06-21-06	NEW DRAWING
REV.	DATE	DESCRIPTION

TYPE 1
BOX CULVERT
INSTALLATION
JENSEN PRECAST